



Rotary Form, Fill and Seal Machines FBM S1 and FBM D2

Horizontally working rotary machines with 8 stations, to form, fill and seal flat or stand-up pouches made from reel, also with reclosure systems.

Application range: Food, Pet Food, Seed Industry, Beverages, Pharmaceuticals, Nonfood, Household, Personal Care

- Hygienic construction and easy cleaning
- Operation and machine status via touch-screen
- High quality construction and long life machine components
- Dosing equipment: Slide doser, auger doser, scales, micro doser for smallest volumes, rotary and valve pumpdoser, seed dosing equipment, doser for individual goods
- Peripheral units can be easily integrated
- Synchronization with linear and multi-head weigher



Uniquely customized.
Uniquely economical.

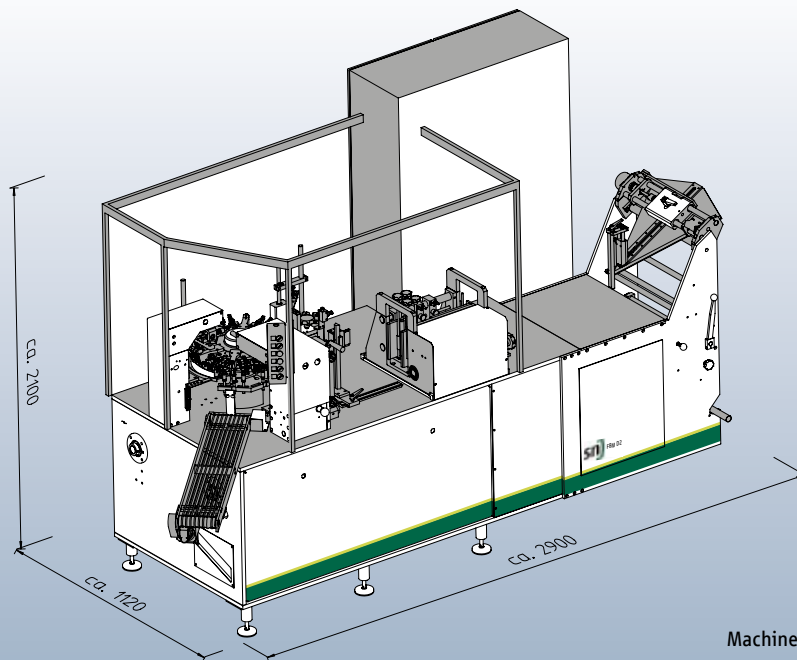

Machine illustrated schematically

Technical details FBM S1 and FBM D2

Specifications	FBM S1 SIMPLEX	FBM D2 DUPLEX
Pouch size [mm]	Width 40 - 180 Length 50 - 210	Width 40 - 90 Length 50 - 210
Machine output [Pouches/min]	up to 100* * depending on filling characteristics and pouch size	up to 200*
Packing material	sealable laminated film	
Construction	Standard to process dry products Optional wash down construction	
Safety equipment	Acc. to the international safety regulations e.g. CE , UL, CSA, OSHA	
Electricity power [kVA]	ca. 5 - 7,5 ¹⁾	
Electricity supply	3 x 400/230V + N + PE, 50/60 HZ	
Voltage [V]	400 / 230 / 24	
Air consumption	300 NI/min, 6 bar ¹⁾	
Machine dimensions L x W x H [mm]	ca. 2.500 x 1.150 x 2.100 ¹⁾	

¹⁾ Depending on configuration. Technical modifications reserved.

Standard equipment	Optional equipment
Two filling stations	Film edge control
Electronic cam control via PLC	Date code systems
Temperature control via PLC	Pouch control (no pouch – no filling)
Operation and adjustment via touch-screen	Empty pouch rejection
Teleservice	Recipe management
	Nitrogen gassing
	Further details on request

